



# SAM PuttLab

The revolution in short game golf training

Project: 16th October 2014  
Player: Hopley, Martin  
File: WHP 7  
Date: 16.10.2014



## Face at address

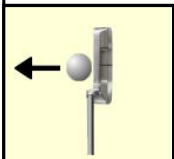
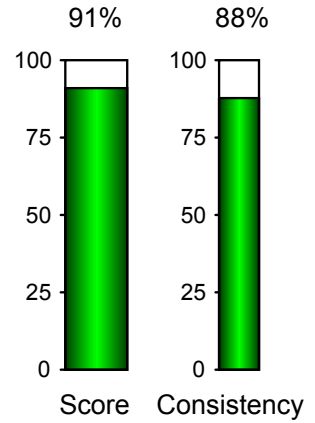
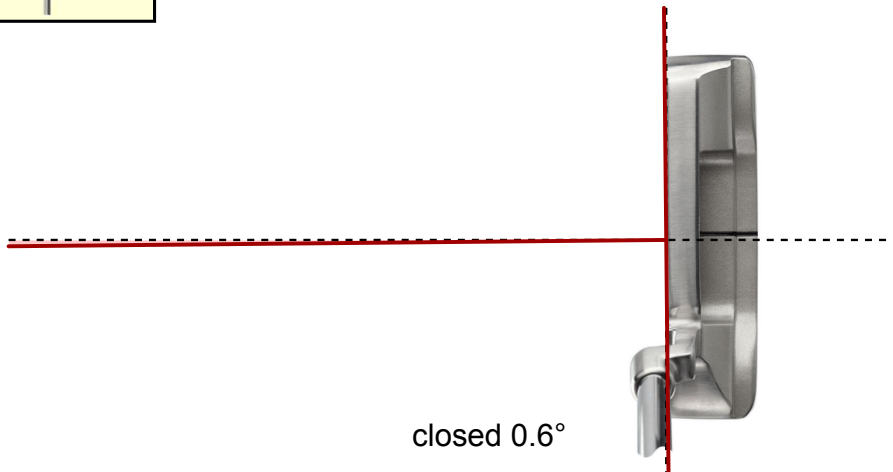

## Face at impact

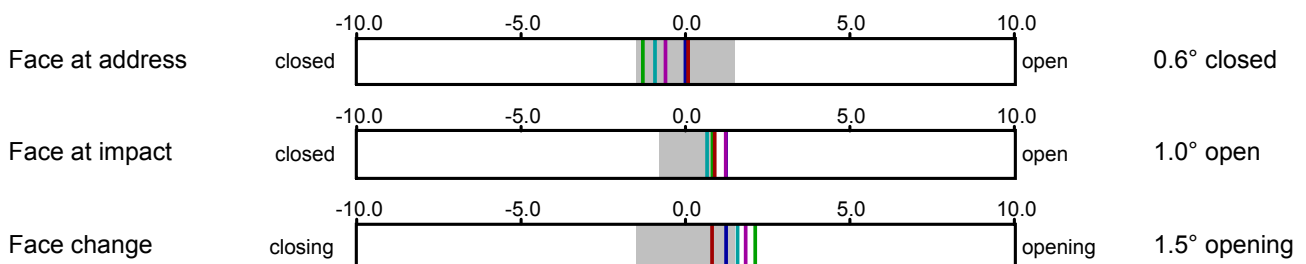
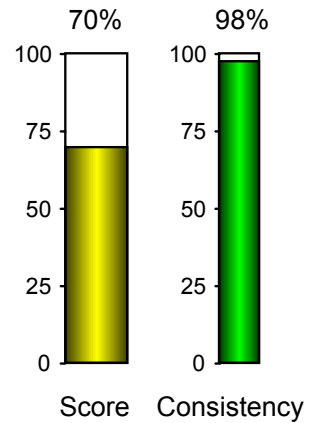
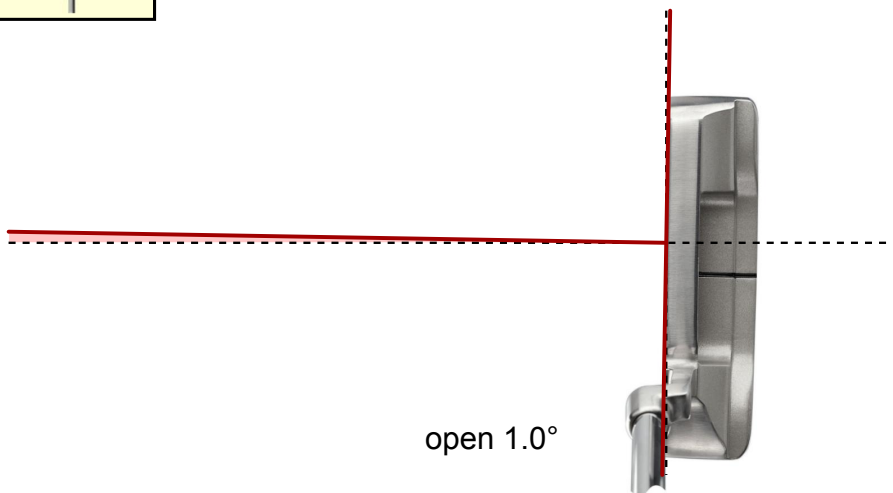



# SAM PuttLab

The revolution in short game golf training

Project: 16th October 2014  
Player: Hopley, Martin  
File: WHP 7  
Date: 16.10.2014

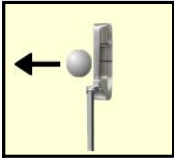

## Putter path - top view

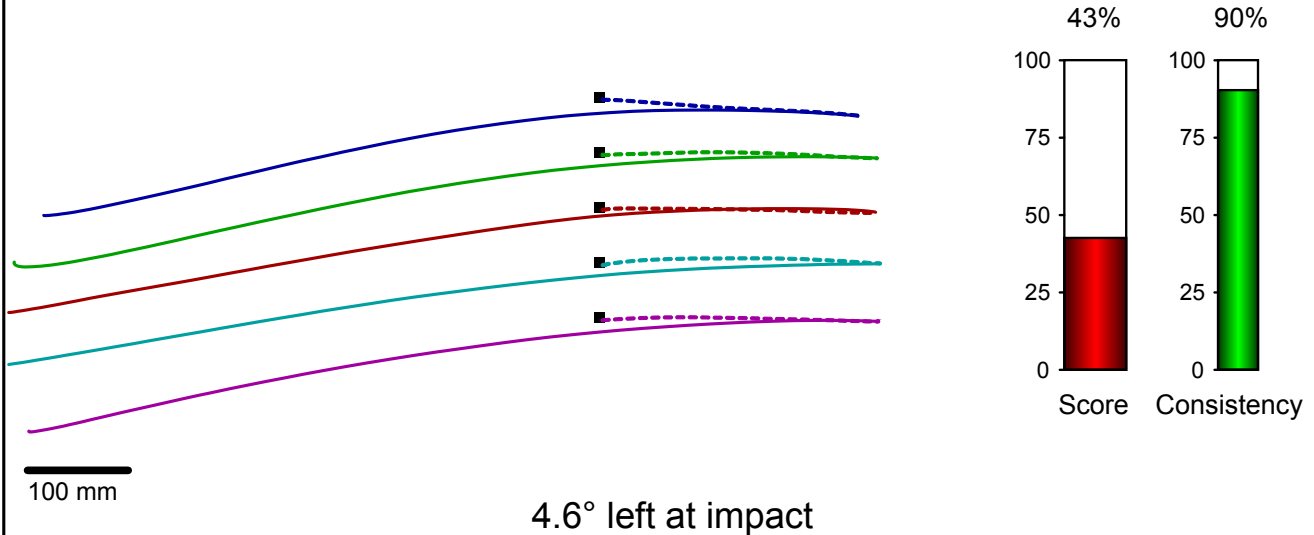

## Impact spot

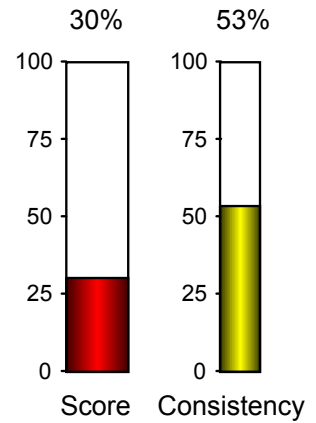
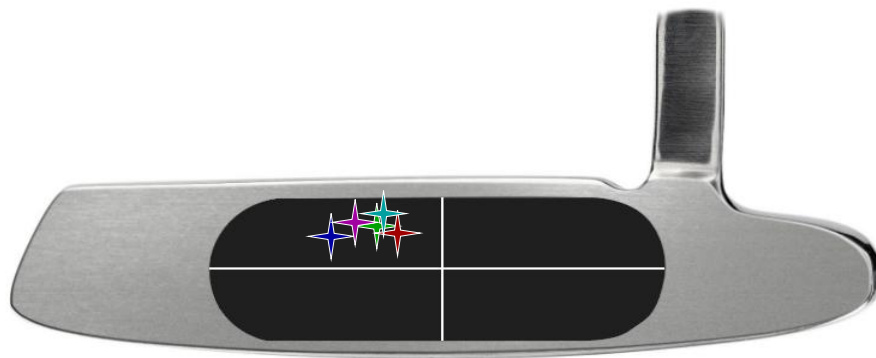

10.1 mm toe

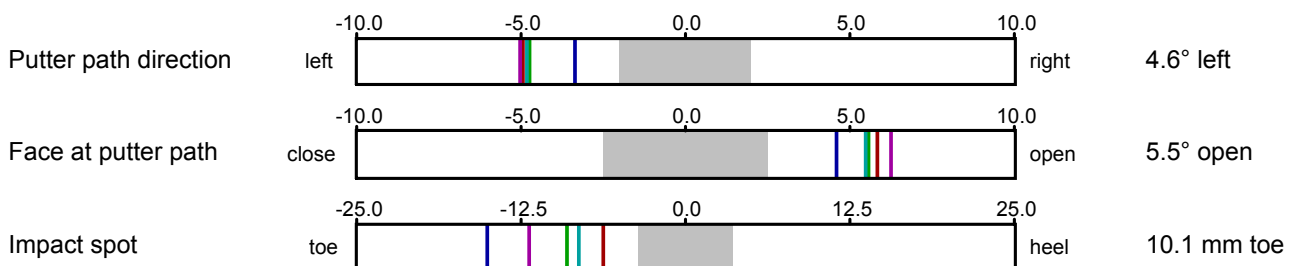



# SAM PuttLab

The revolution in short game golf training

Project:	16th October 2014
Player:	Hopley, Martin
File:	WHP 7
Date:	16.10.2014

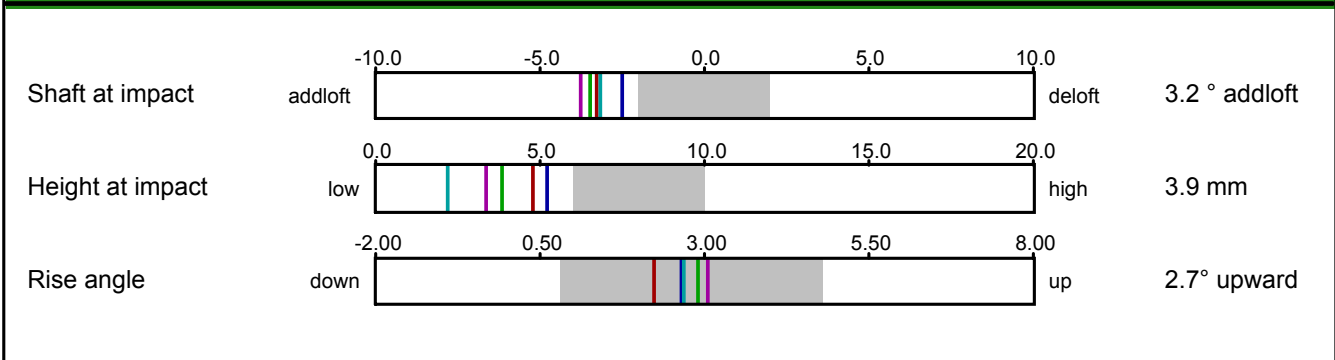
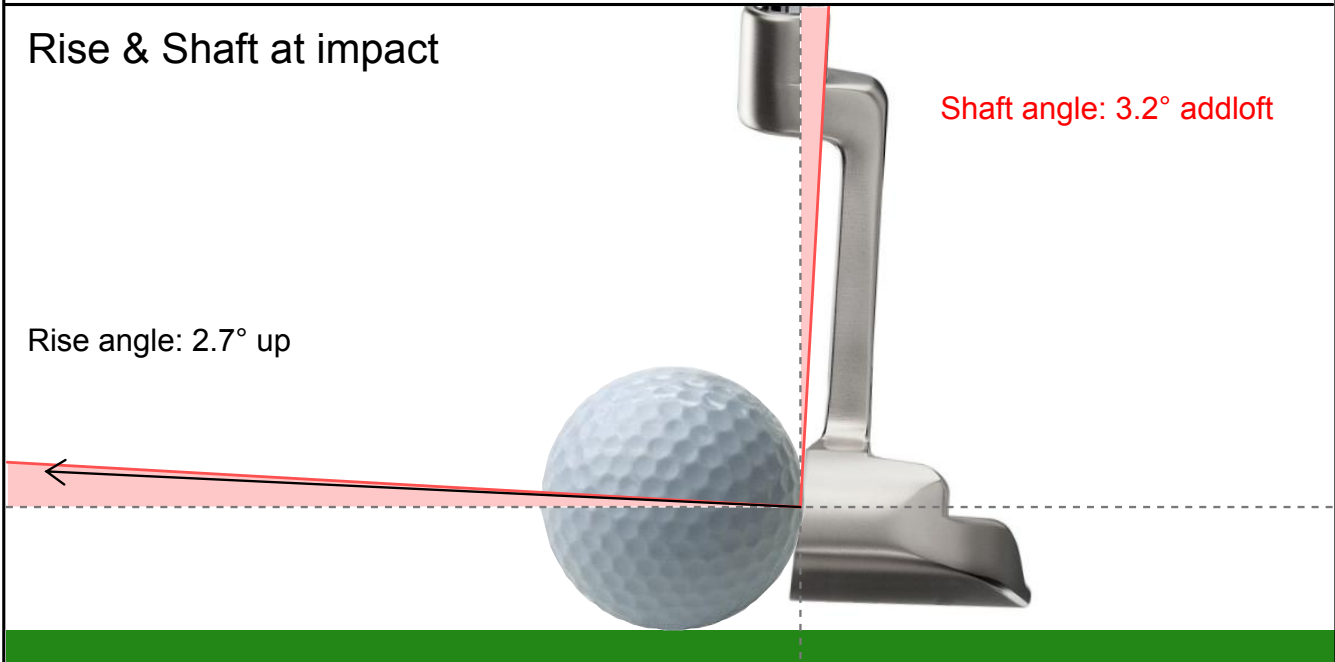
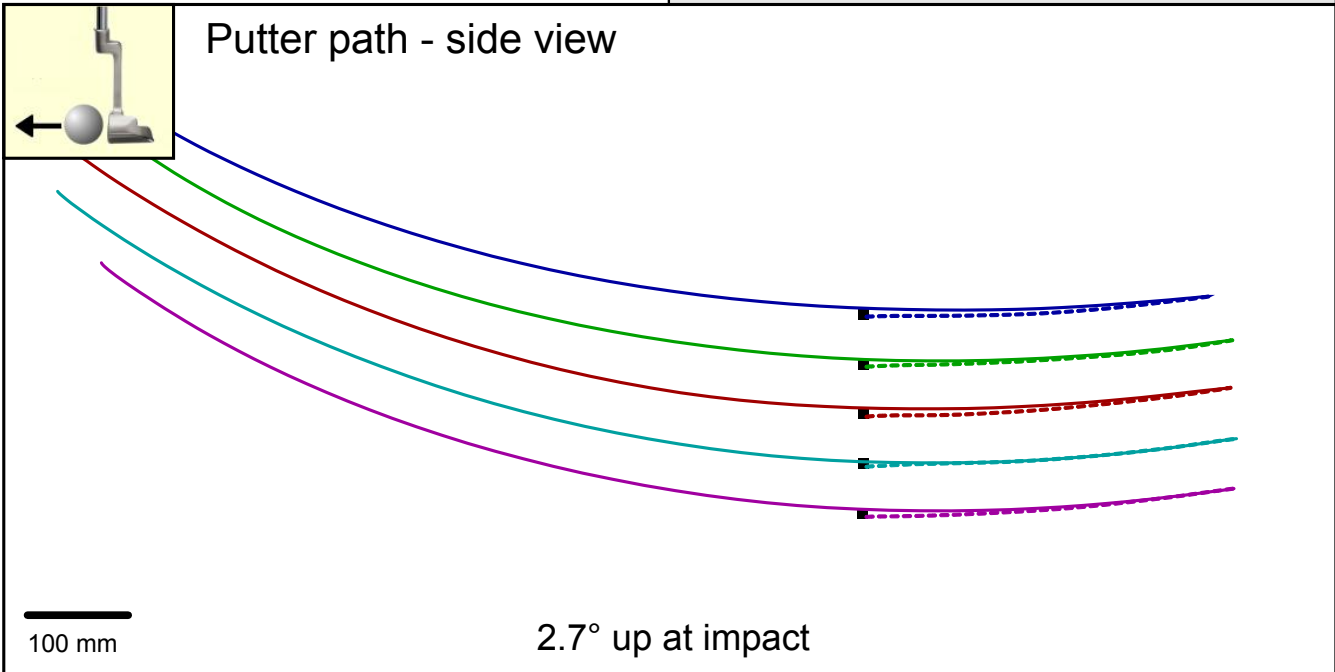



Project: 16th October 2014  
Player: Hopley, Martin  
File: WHP 7  
Date: 16.10.2014

### Clubhead Rotation

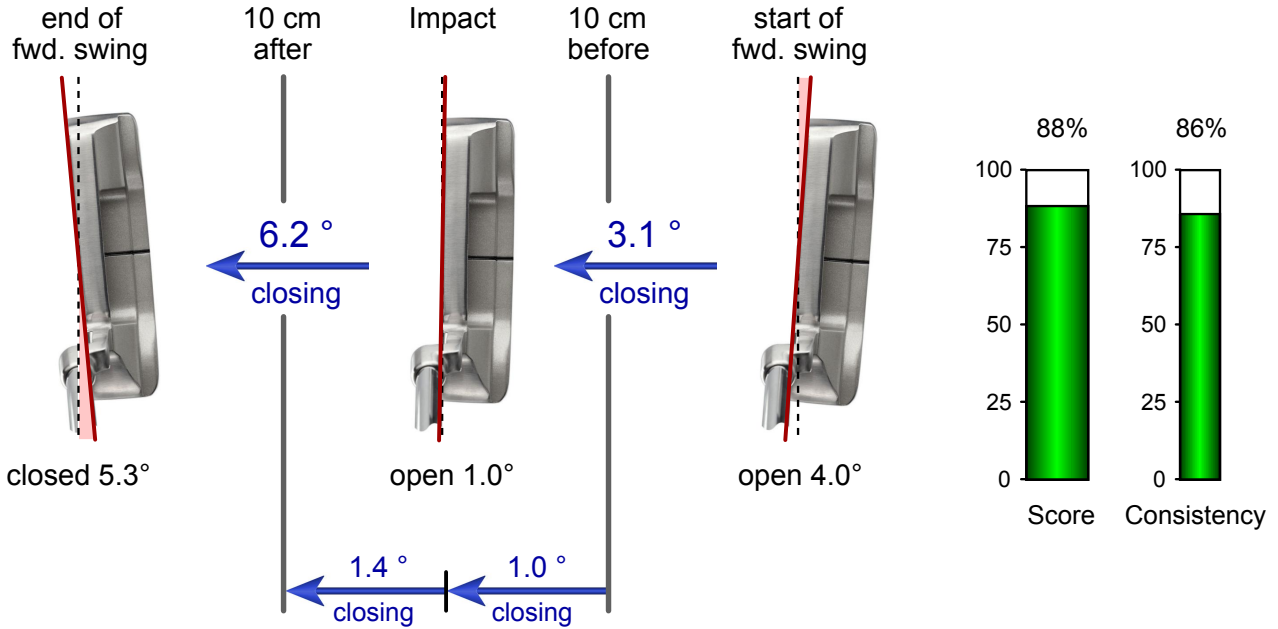

### Rotation

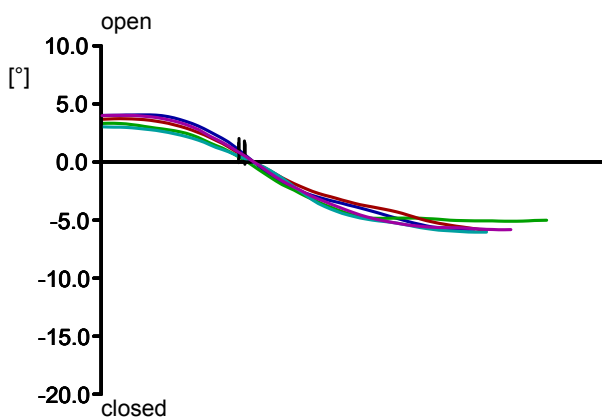

### Rate of Rotation

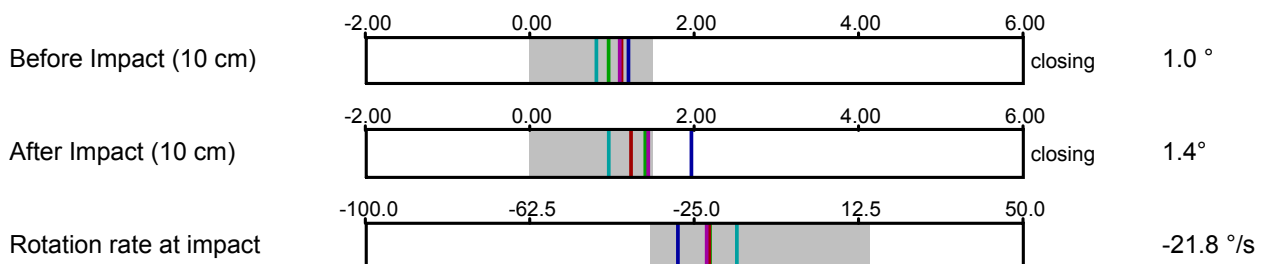
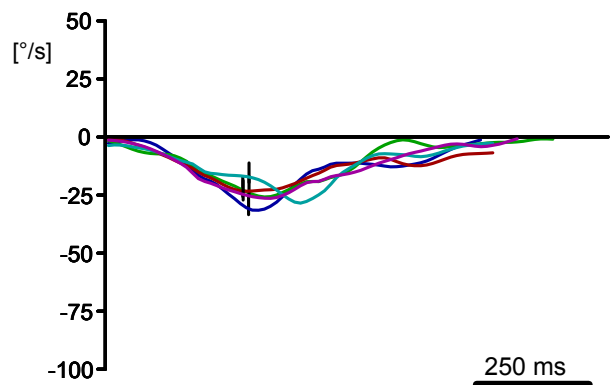



Project: 16th October 2014  
Player: Hopley, Martin  
File: WHP 7  
Date: 16.10.2014

### Movement Dynamics

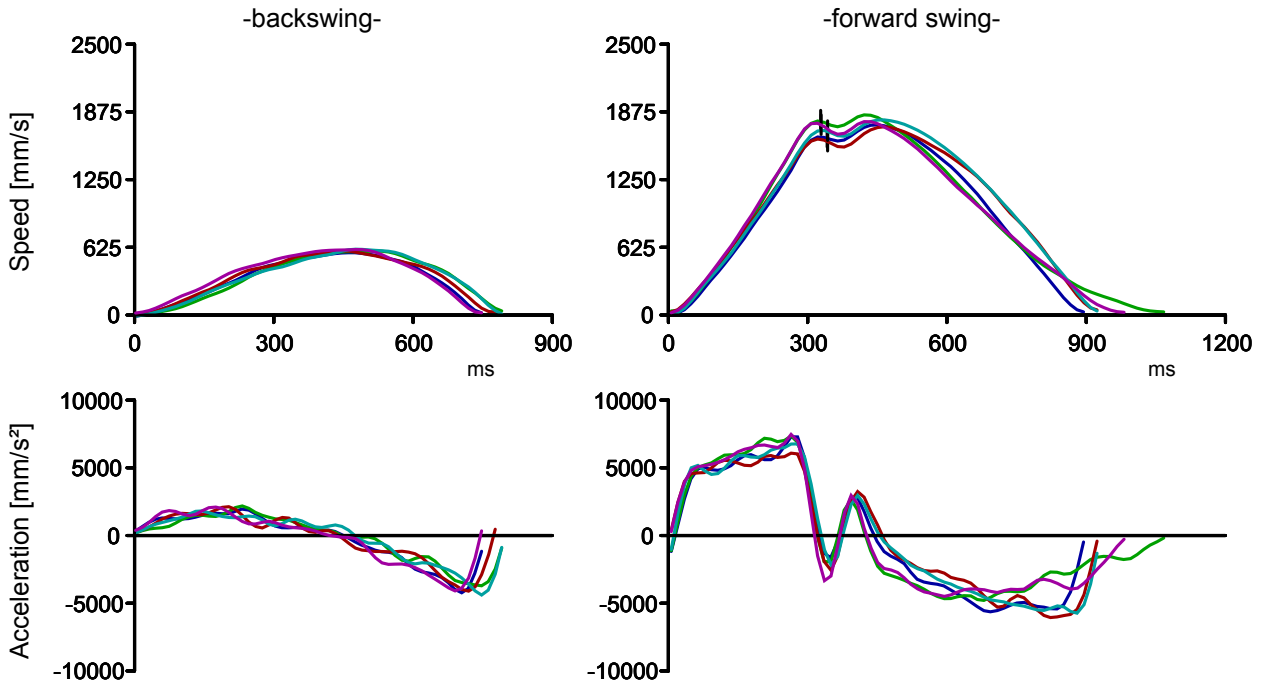

### Timing

